

Centerless Wheels

		TIER: BEST		BETTER		BETTER		GOOD	
		QUANTUM CENTURY45 CENTERLESS RESINOID WHEELS		32AC / 32AC CENTURY 45 CENTERLESS RESINOID WHEELS		55A CENTERLESS VITRIFIED WHEELS		53A, 57A, 64A, GEMINI, GEMIN2 CENTERLESS VITRIFIED WHEELS	
		Ceramic Alumina		Aluminum Oxide/Silicon Carbide		Aluminum Oxide		Aluminum Oxide	
SIZE (D x T x H)	STD. PKG.	SPEC.	PART #	SPEC.	PART #	SPEC.	PART #	SPEC.	PART #
Type 01 Straight									
16 x 4 x 10	1							57A80-L8VCN	662534 65001
20 x 2 x 12	1								
20 x 4 x 12	1							64A60-KVCE	690786 66723
	1							64A80-LVCE	690786 66727
20 x 6 x 12	1	2NQMC54-QB45	662434 96406	32AC80-NB45	662434 96398	55A60-KVS3	662533 87817	64A60-KVCE	690786 66729
	1			32AC54-QB	690786 66545	55A80-LVS	662534 90781	Gemini 60-L	662532 46994
	1					55A80-MVS	662534 90788		
20 x 8 x 12	1	2NQMC54-QB45	662434 96407	32AC80-NB45	662434 96400	55A60-KVS3	662533 87819	64A60-KVCE	690786 66748
	1			32AC54-QB	690786 66546	55A80-LVS	662534 90783	64A60-LVCE	690786 66749
	1					55A80-MVS	662534 90785	64A80-KVCE	690786 66751
	1							Gemini 54-J	662532 47001
	1							Gemini2 60-K	662534 51857
24 x 2-1/2 x 12	1							57A A80/120 P/R	662534 91223
24 x 2-1/2 x 12	1							57A 80/120 O/Q	662532 85629
w/ 3/16" fine/hard layer	1							57A 80/120 P/R	662533 40540
24 x 3 x 12	1							64A60-K8V127	690831 66708
24 x 4 x 12	1							Gemini2 60-K	662534 51860
	1							Gemini2 100-L	662534 51861
24 x 6 x 12	1	2NQMC54-QB45	662434 96408	32AC80-NB45	662434 96401	55A80-LVS3	662533 87821	Gemini 60-K	662532 47047
	1			32AC54-QB	690831 66547			Gemini2 60-K	662534 51862
24 x 8 x 12	1	2NQMC54-QB45	662434 96409	32AC80-NB45	662434 96403	55A60-KVS	662534 90791	Gemini2 60-K	662534 51864
	1			32AC54-QB	690831 66548	55A60-LVS	662534 90762		
	1					55A80-LVS3	662533 87825		
	1					55A60-MVS	662534 90782		
24 x 10 x 12	1	2NQMC54-QB45	662434 96410	32AC80-NB45	662434 96404	55A60-KVS3	662533 87830	Gemini2 60-K	662534 51866
	1			32AC54-QB	690831 66549	55A80-LVS3	662533 87828		
24 x 20 x 12	1			32AC54-QB	690831 66552				
Composed of 2 Wheels	1			32AC54-SB	690831 66553				
10" Thick (ME90362)									

Rubber Bond Feed Wheels

		TIER: BETTER	
		ABRASIVE: Aluminum Oxide	
SIZE (D x T x H)	STD. PKG.	SPEC.	PART #
Type 07 Recessed Two Sides			
12 x 4 x 5	1	57A80-RR51	662532 22844
Rec 2 Sides 7-1/2 x 1/2			
12 x 6 x 5	1	57A80-RR51	662532 22846
Rec Side A 7-1/2 x 1-1/2			
Rec Side B 7-1/2 x 1/2			
12 x 6 x 5	1	57A80-RR51	662532 22847
Rec 2 Sides 7-1/2 x 1-1/2			
12 x 8 x 5	1	57A80-RR51	662532 22850
Rec Side A 7-1/2 x 2-1/2			
Rec Side B 7-1/2 x 1-1/2			
14 x 8 x 5	1	57A80-RR51	662533 22859
Rec Side A 8 x 2			
Rec Side B 8 x 1-1/2			
14 x 20 x 6	1	57A80-RR51	662533 22196
Rec 2 Sides 8-1/2 x 1-1/2			
Butted Feed Wheels			
Composed of 2 Wheels			
10" Thick (ME91512)			

Plastic Bond Feed Wheels

		TIER: BETTER	
		ABRASIVE: Aluminum Oxide	
SIZE (D x T x H)	STD. PKG.	SPEC.	PART #
Type 07 Recessed Two Sides			
12 x 8 x 5	1	57A80-RP4	662532 22199
Rec Side A 7-1/2 x 2-1/2			
Rec Side B 7-1/2 x 1-1/2			

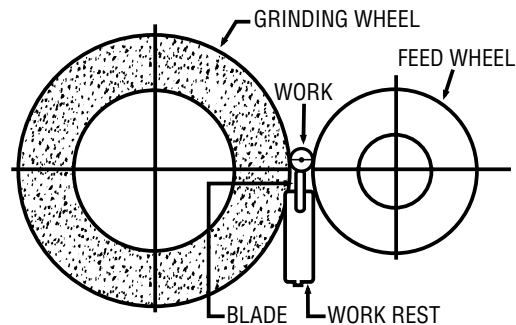

There are many more sizes and specifications available made-to-your-order, including wheels made from our blank stock FastTrack Service for rush orders. Ask about wheels made with our revolutionary new premium Quantum Prime ceramic grain. Contact your Norton representative with your custom centerless requirements.